

REVISIONS				
ZONE	REV.	DESCRIPTION	DATE	APPROVED
	A	DRAFT RELEASE	2012-03-03	AJM
	B	UPDATED VARIOUS PART NUMBERS AND DESCRIPTIONS IN BOM	3/10/2012	AJM
	C	BOM CORRECTION INDUCING TRUSS HEAD SCREW SIZE	3/11/2012	AJM
	D	ADD EXTRUDER AND MOUNTING HARDWARE, CONVERT TO PAN HEAD SCREWS	3/18/2012	AJM

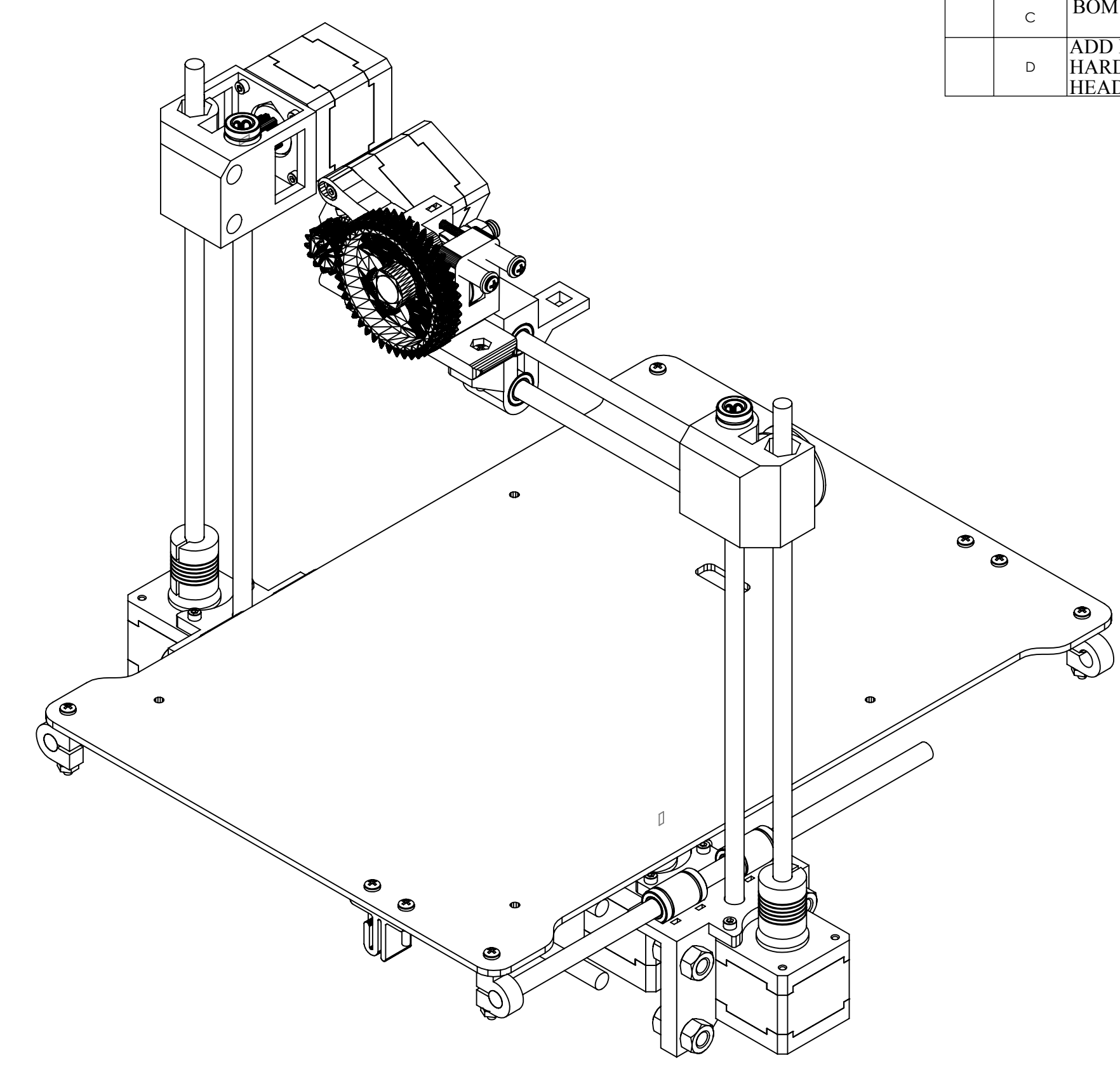
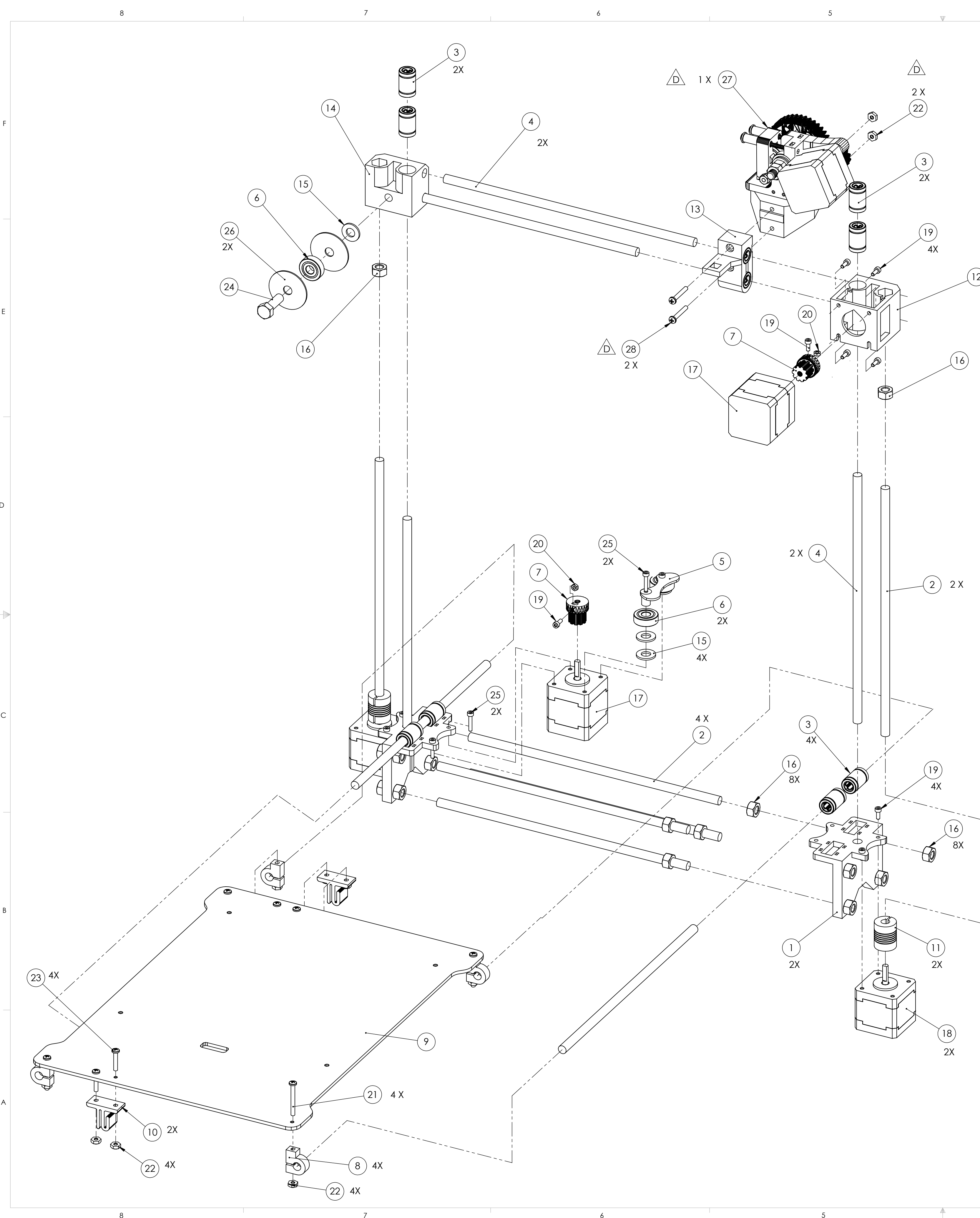

# INITIAL DRAFT

ITEM NO.	PART NUMBER	QTY.	DESCRIPTION
1	1003-02	2	PB-BASE-V2
2	1005-01	6	5/16-18 X 10 THREADED ROD
3	1019-01	10	LM8 8MM - LM8UU LINEAR BALL BEARING
4	1007-02	6	M8 LINEAR ROD 10IN
5	1002-01	1	PB-Y-BEARING-GUIDE
6	1020-01	3	608ZZ BALL BEARING 8X22X7 SHIELDED
7	1008-01	2	10 TOOTH XL PULLEY
8	1001-01	4	PB-Y-BAREND
9	1009-02	1	BUILD PLATFORM
10	1010-01	2	PB-BELTCLIP
11	1011-01	2	5MM TO 8MM FLEXIBLE SHAFT COUPLING
12	1015-02	1	PB-X-MOTOR-V2
13	1012-02	1	PB-X-CARRIAGE-V2
14	1013-01	1	PB-X-IDLER
15	1021-01	5	ANSI/ASME B18.22.1 SAE TYPE A FLAT WASHER 5/16" SIZE, 11/16" OD, PLAIN STEEL
16	1018-01	18	ANSI/ASME B18.2.2 5/16"-18 HEX NUT 1/2" W, 17/64" H ZNC-PLTD STL LOW-STRENGTH
17	1006-02	2	NEMA 17 STEPPER MOTORS, HIGH TORQUE
18	1006-01	2	NEMA 17 STEPPER MOTORS, MEDIUM TORQUE
19	1016-04	8	DIN 912/ISO 4762 M3 X 8 12.9 ALLOY STEEL BLAC
20	1022-01	2	ISO - 4032/DIN 934, M3, HEX NUT, 2.4MM H, ZNC-PLTD STEEL
21	1023-11	4	PAN HEAD MACHINE SCREW, #6-32 X 1 1/2" L, PHILLIPS, 18-8 SS
22	1024-01	10	ANSI/ASME B18.6.3, MACHINE SCREW HEX NUTS, 6-32 SIZE, ZNC-PLTD STEEL
23	1023-08	4	PAN HEAD MACHINE SCREW, #6-32 X 3/4" L, PHILLIPS, 18-8 SS
24	1017-01	1	ASME B18.2.1 / ASTM A307 5/16"-18 X 1" HEX BOLT ZNC-PLTD STL LOW-STRENGTH
25	1016-09	6	DIN 912/ISO 4762 M3 X 16 12.9 ALLOY STEEL BLACK
26	1025-01	2	LARGE-DIAMETER FLAT WASHER 5/16" SCREW SIZE, 1-1/2" OD, .05"-.08" THICK
27	1026-01	1	EXTRUDER ASSEMBLY
28	1048-13	2	PAN HEAD MACHINE SCREW, #6-32 X 1" L, PHILLIPS, 18-8 SS

△ D  
△ D  
△ D  
△ D

UNLESS OTHERWISE SPECIFIED:  
 DIMENSIONS ARE IN INCHES  
 TOLERANCES:  
 FRACTIONAL ±  
 ANGULAR: MACH ±  
 BEND ±  
 TWO PLACE DECIMAL ±  
 THREE PLACE DECIMAL ±

THE INFORMATION CONTAINED IN THIS DRAWING IS THE SOLE PROPERTY OF ALEX MADSEN. ANY REPRODUCTION IN PART OR AS A WHOLE WITHOUT THE WRITTEN PERMISSION OF ALEX MADSEN IS PROHIBITED. COPYRIGHT 2012

INTERPRET GEOMETRIC TOLERANCING PER: MATERIAL FINISH

NAME	DATE
A. MADSEN	2012-3-3

DRAWN: A. MADSEN  
 CHECKED: B. DRUMM  
 DESIGN: MFG APPR: G.A.  
 COMMENTS:

TITLE: PRINTRBOT ASM

SIZE DWG. NO. REV  
 D 1004-01 D  
 SCALE: 1:2 WEIGHT: SHEET 1 OF 1